

SLPV - 35 is seatless & glandless piston valve in forged carbon steel construction. Maintenance free design suitable for varied applications.



### UNIQUE FEATURES

- Heat resistant hand wheel
- Wear & Erosion resistance for most of the fluids
- Unique sealing arrangement for extended life of Valve
- Class VI leakage Valve
- Use of Belleville washer to compensate thermal expansion

### DIMENSIONS

Size	SCR/SW (L)	#150 (L)	#300 (L)	H
15 NB	107	187	197	150
20 NB	107	191	201	150
25 NB	126	216	228	174
32 NB	165	259	275	238
40NB	165	267	281	238

### SIZE

15 NB, 20 NB, 25 NB, 32 NB, 40 NB

### PIPE CONNECTIONS

**Screwed :** BSP, BSPT, NPT

**Socket Weld**

**Flanged :** ASA 150, ASA 300  
(Weld on)

### DESIGN CONDITIONS

END Connection	Max. Allowable Pressure (PMA) bar (g)	Max. Allowable Temp (TMA)
BSP	20	425
BSPT/NPT	31.6	425
Socket Weld	76.4	425
# ASA150	13.8	200
# ASA300	34.7	400

### CERTIFICATION

IBR approval / En 10204 3.1

### INSTALLATION

- SLPV - 35 can be installed both horizontally as well as vertically according to pipe line requirement.
- Valve is bi-directional but preferred to install valve as per arrow direction on the valve.
- Ensure proper flushing of line before installation.
- Periodic lubrication of valve is required for smooth functioning.

**CONSTRUCTION**

Size : 15NB, 20NB, 25NB

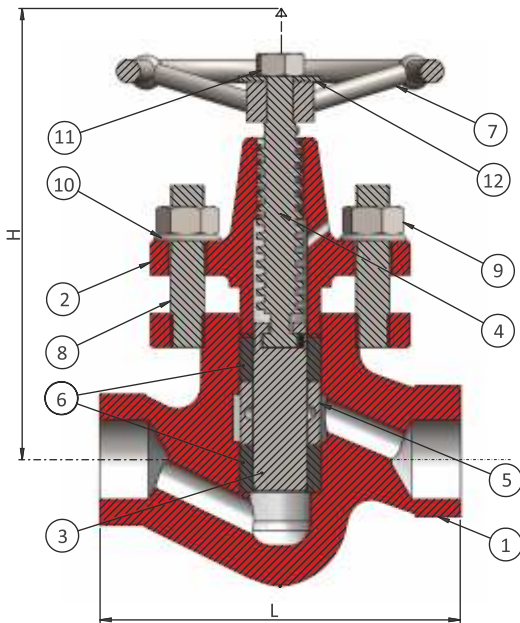

Size : 32NB & 40NB

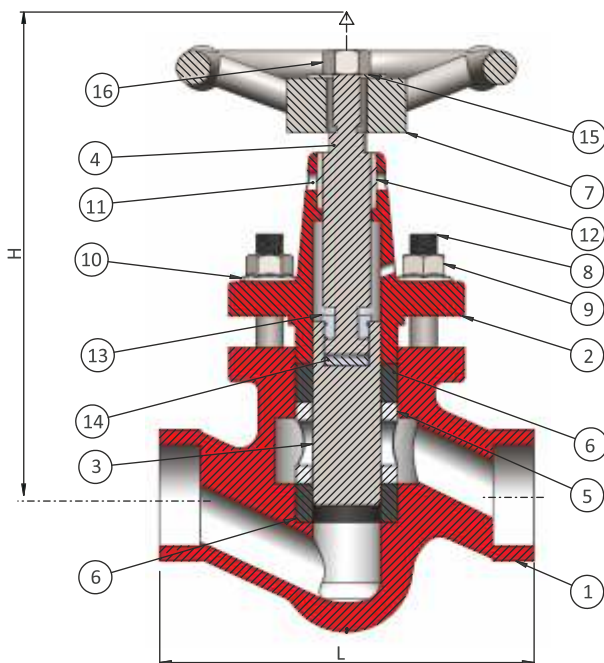

**HOW TO ORDER**

Ex. SLPV - 35 forged Carbon steel piston valve,  
15NB socket weld connection, IBR.

**PART LIST :**

Size : 15NB, 20NB, 25NB

No.	Part Name	Material	Qty
1	Body	ASTM A 105	1
2	Bonnet	ASTM A 105	1
3	Piston	AISI 304	1
4	Spindle	AISI 420	1
5	Lantern Ring	AISI 420	1
6	Seal Ring Assembly	Graphite + AISI 304	2
7	Hand Wheel	Fiber Glass	1
8	Stud	ASTM A 193 Gr. B7	2
9	Nut	ASTM A 194 Gr. 2H	2
10	Belleville Washer	Spring Steel 50Cr. V4	4
11	Hand Wheel Lock Nut	AISI 304	1
12	Name plate	AISI 304	1

\* Note : For 25NB, Item no. 8,9,10 required twice the above mentioned quantity.

Size : 32NB & 40NB

No.	Part Name	Material	Qty
1-7	Same as 15NB, 20NB, 25NB		
8	Stud	ASTM A 193 Gr. B7	4
9	Nut	ASTM A 194 Gr. 2H	4
10	Belleville Washer	Spring Steel 50Cr. V4	8
11	Spindle Bush	AL Bronze	1
12	Bush Retainer	Spring Steel	1
13	Split Nut	Brass	1
14	Thrust Disc	AISI 420 + H.T.	1
15	Name plate	AISI 304	1
16	Hand wheel Nut	AISI 304	1

**SPARE PARTS**

- Seal ring Assembly (set of 5)
- Spindle (set of 5)
- Split nut (Set of 5)

**Steamlok Engineering Pvt. Ltd.**

W75 S Block MIDC Bhosari Pune, Maharashtra - 411026, India  
Email : sales@steamlokengineering.com • Website : www.steamlokengineering.com

**STEAM SOLUTION GROUP**