

SLFT-70 is a uniquely designed ball float steam tap in cast Iron (FG-260) construction with unique SLR, rotating ball & seat design.



SIZE

15 NB, 20 NB, 25 NB

END CONNECTIONS

Screwed : BSP, BSPT, NPT

DESIGN CONDITIONS

- Max. operating Pressure (PMA) - 14 Bar (g)
- Max. Operating Temperature (TMA) 220° C
- Max. Differential Pressure (ΔP_{max})
SLFT70 - 05 - 05 bar (g)
SLFT70 - 10 - 10 bar (g)
SLFT70 - 13 - 13 bar (g)

INSTALLATION

- Trap must be installed in horizontal direction with arrow direction on nameplate pointing downward.
- Inlet direction arrow should be inline with flow direction of pipe. Ensure proper flushing of line before installation of trap.
- Suitable size strainer is recommended before trap for smooth operation of trap.
- Slow opening of isolation valve is recommended to avoid system shock.

UNIQUE FEATURES

- Unique rotating ball design makes trap zero leak, **Patented Design**
- Self aligning steamlock release (SLR)
- Functional Test - 100% on steam

DISCHARGE CAPACITY (Kg/hr)

MODEL	SIZE	DIFFERENTIAL PRESSURE(BAR)												
		0.5	1	1.5	2	2.5	3	3.5	4	4.5	5	5.5	6	6.5
SLFT70-5	15NB,20NB	240	336	418	487	546	600	647	696	740	781	-	-	-
SLFT70-10	15NB,20NB	130	182	227	264	296	325	351	378	401	424	445	466	486
SLFT70-13	15NB,20NB	54	75	94	109	122	134	145	156	166	175	184	192	200
SLFT70-5	25NB	598	837	1042	1213	1360	1495	1612	1735	1842	1947	-	-	-
SLFT70-10	25NB	266	372	463	539	605	664	716	770	819	865	909	952	992
SLFT70-13	25NB	130	182	227	264	296	325	351	378	401	424	446	466	486
MODEL	SIZE	DIFFERENTIAL PRESSURE(BAR)												
		7	7.5	8	8.5	9	9.5	10	10.5	11	11.5	12	12.5	13
SLFT70-5	15NB,20NB	-	-	-	-	-	-	-	-	-	-	-	-	-
SLFT70-10	15NB,20NB	505	524	541	560	576	592	609	-	-	-	-	-	-
SLFT70-13	15NB,20NB	208	216	224	231	238	245	251	258	265	271	278	284	290
SLFT70-5	25NB	-	-	-	-	-	-	-	-	-	-	-	-	-
SLFT70-10	25NB	1031	1069	1105	1141	1176	1209	1243	-	-	-	-	-	-
SLFT70-13	25NB	505	524	542	560	576	593	609	625	641	657	673	688	703

CONSTRUCTION

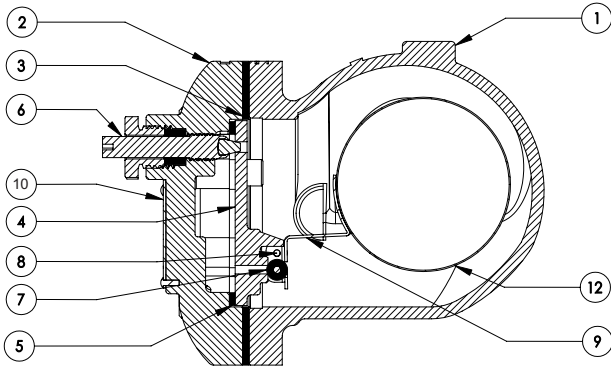

DIMENSIONS

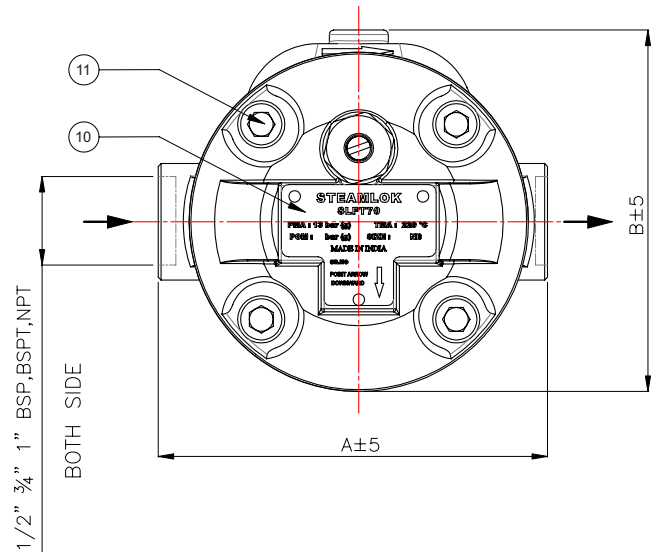

PART LIST

NO	DESCRIPTION	MATERIAL	QTY
1	BODY	CI FG-260	1
2	COVER		1
3	COVER GASKET	NON CAF GRADE AF 154	1
4	SEAT PLATE	AISI 304	1
5	SEAT PLATE GASKET	NON CAF GRADE AF 154	1
6	SLR ASSEMBLY	AISI 304	1
7	BALL	AISI 440C	1
8	PIN	AISI 304	1
9	LEVER	AISI 304	1
10	NAME PLATE	AISI 304	1
11	BOLT	HIGH TENSILE Gr.10.9	4
12	FLOAT ASSEMBLY	AISI 304	1

HOW TO ORDER

Ex. SLFT-70, Ball Flot Steam Trap,
in Cast Iron, 15NB,
Screwed BSPT, 5 Bar (g), SLR
Non - IBR

SCREWED

SLFT70	A (MM)	B (MM)	WEIGHT (Approx.)
15-20 NB	132	123	3.5 KG.
25 NB	140	144	5 KG.

CERTIFICATION

En10204 3.1

SPARE PARTS

- Float Assembly
- SLR Assembly (set of 5)
- Cover Gasket (set of 5)
- Seat plate gasket (set of 5)

SteamLok Engineering Pvt. Ltd.

W-75, S Block, MIDC Bhosari, Pune, Maharashtra, 411026 India

Email : sales@steamlokengineering.com Website : www.steamlokengineering.com

STEAM SOLUTION GROUP